

Self-righting non illuminated bollard

Notes

1. Screws/washers to be stainless steel, spacers to be rigid pvc.
2. White body - black may be specified in heritage/selected areas.
3. If restricted depth, anchor fixings may be cut down but increase width of excavation hole to allow same volume of concrete as shown with un-cut fixings.
4. Bollard must have 2 x conspicuity panels per site.
5. Alternative self righting bollard type may be considered upon application to overseeing authority.

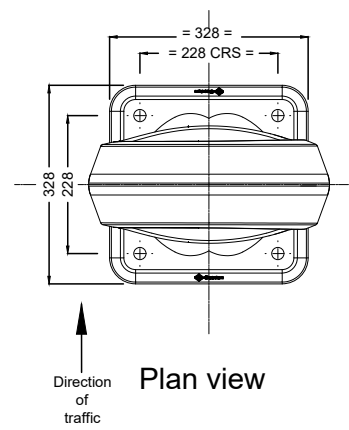
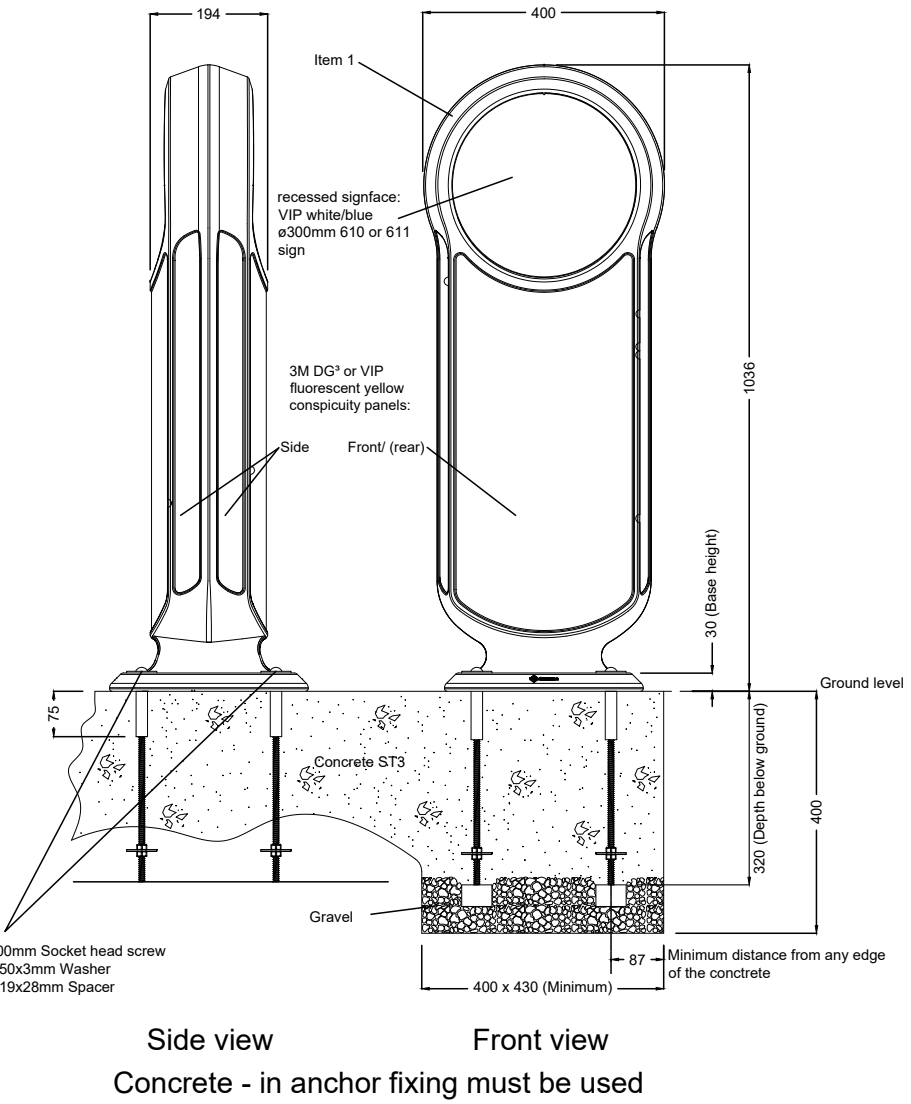

| | | | |
|-------------------|-------|--------------|--------------|
| Rev: | Date: | Description: | Approved by: |
| AMENDMENT DETAILS | | | |

Lincolnshire
COUNTY COUNCIL
Working for a better future

| | | | |
|-------------|----|--------------|----|
| Checked by: | GP | Approved by: | SB |
|-------------|----|--------------|----|

| | |
|--------|----------|
| ISSUED | 12/05/17 |
|--------|----------|

Self-Righting
Non-Illuminated Bollard

This is a typical detail and may require conversion to a full scheme specific drawing.

NOT TO SCALE
(all units in millimetres)

Disclaimer : Before making use of this detail, any designer or third party must ensure that it satisfies all requirements of the scheme to which it is being applied. Lincolnshire County Council accept no responsibility for third party use of this Standard Detail.

SD/12/7
Standard Detail Number

Revision Number

SD/12/7

Revision