

Notes

- 1. Based on 'Lincolnshire Design Guide for Residential Areas'

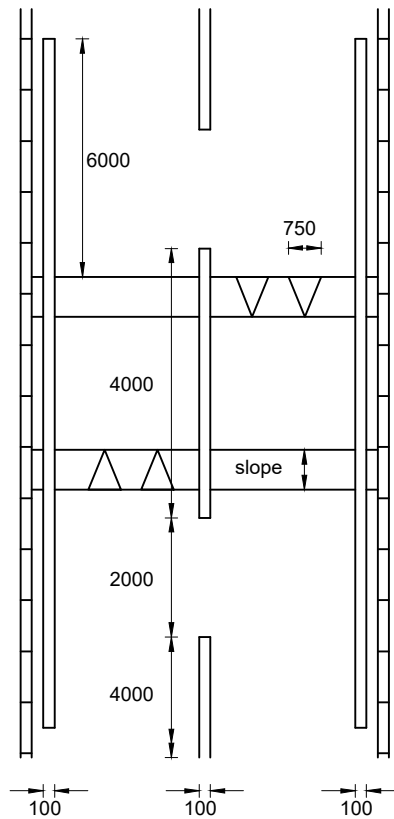

Flat Top Hump - Full Width

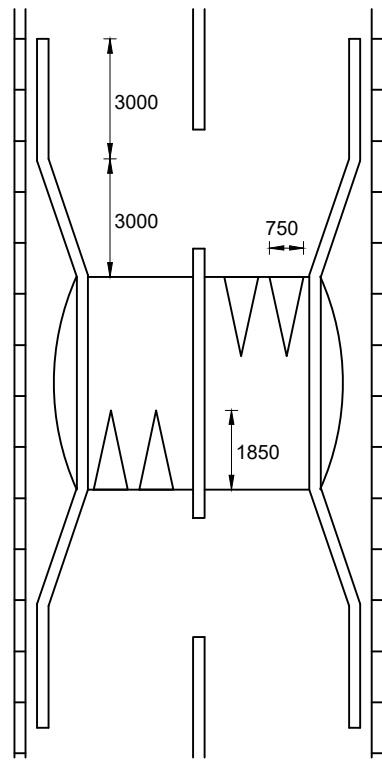

Round Top Hump - Tapered Edge

Rev: AMENDMENT DETAILS Date: Description: Approved by:



Checked by: GP Approved by: SB

ISSUED 12/05/17

Signs and Markings for Humps

This is a typical detail and may require conversion to a full scheme specific drawing.

NOT TO SCALE  
(all units in millimetres)

**Disclaimer :** Before making use of this detail, any designer or third party must ensure that it satisfies all requirements of the scheme to which it is being applied. Lincolnshire County Council accept no responsibility for third party use of this Standard Detail.

SD/26/124  
Standard Detail Number

Revision Number