

Notes

1. Based on 'Lincolnshire Design Guide for Residential Areas'
2. Minimum bed on 30% CBR base to be 100mm ST3 concrete or in accordance with manufacturers instructions.

Round Top Hump with Tapered Sides

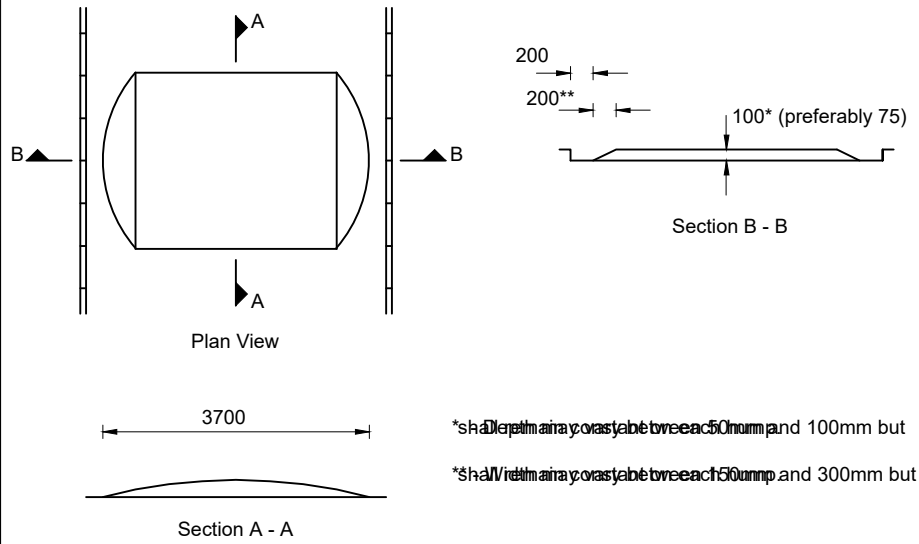

Flat Top Hump with Tapered Sides

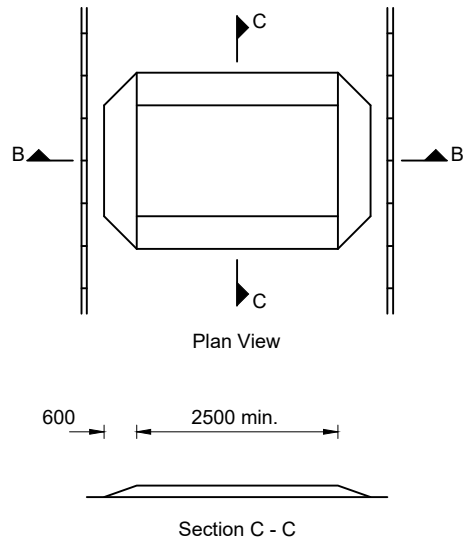

Rev: AMENDMENT DETAILS Date: Description: Approved by:



Checked by: GP Approved by: SB

ISSUED 12/05/17

Road Hump Details

This is a typical detail and may require conversion to a full scheme specific drawing.

NOT TO SCALE
(all units in millimetres)

Disclaimer : Before making use of this detail, any designer or third party must ensure that it satisfies all requirements of the scheme to which it is being applied. Lincolnshire County Council accept no responsibility for third party use of this Standard Detail.

SD/26/123
Standard Detail Number

Revision Number