

Notes

1. Appendices relate to 'Specification for Highway Works'.
2. Where haunching in front of existing or new kerbs (or channel blocks) is less than 350mm ST3 concrete may be used. Depth of layer of ST3 concrete shall be specified in B of Q. Consult Lincs Laboratory for treatment options.
3. Where existing channels blocks are to be retained these shall govern the new surfacing levels.

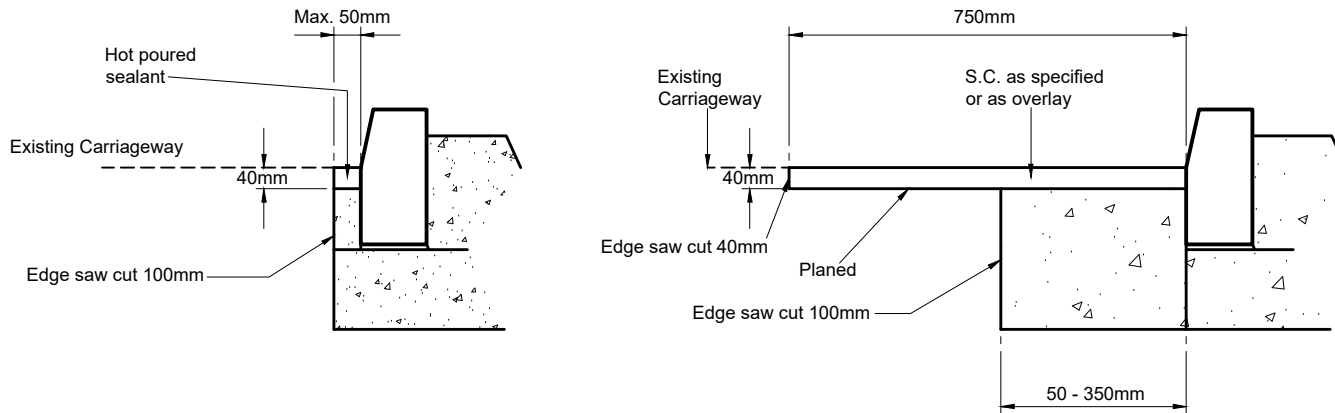

| | | | |
|--|--|--|--|
| | | | |
| | | | |

| | | | |
|-------------------|-------|--------------|--------------|
| Rev: | Date: | Description: | Approved by: |
| AMENDMENT DETAILS | | | |



| | | | |
|-------------|----|--------------|----|
| Checked by: | GP | Approved by: | SB |
|-------------|----|--------------|----|

| | |
|--------|----------|
| ISSUED | 12/05/17 |
|--------|----------|

Haunching Widths Less Than 350mm wide Detail X

| | |
|------------------------|-----------------|
| SD/26/111 | Revision Number |
| Standard Detail Number | |

This is a typical detail and may require conversion to a full scheme specific drawing.

NOT TO SCALE
(all units in millimetres)

Disclaimer : Before making use of this detail, any designer or third party must ensure that it satisfies all requirements of the scheme to which it is being applied. Lincolnshire County Council accept no responsibility for third party use of this Standard Detail.