

Notes

- 1. Finishes to be Class F2.

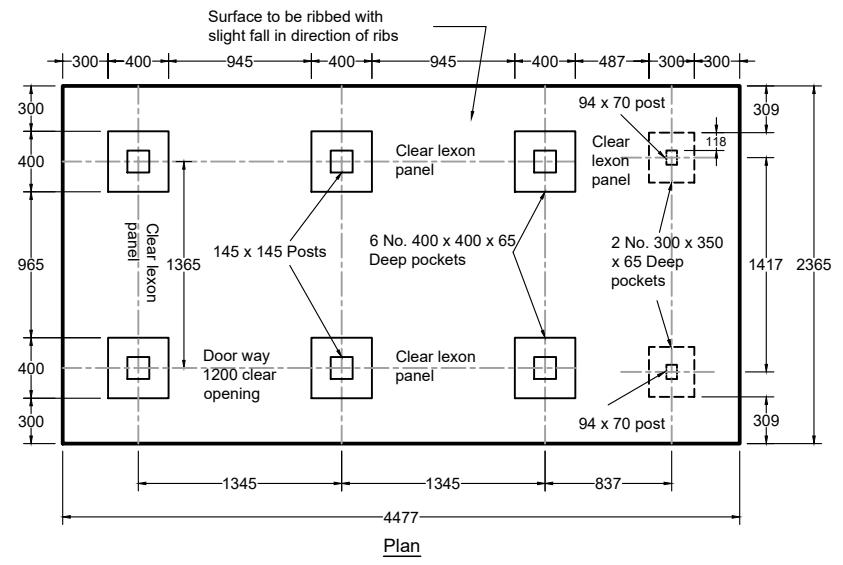
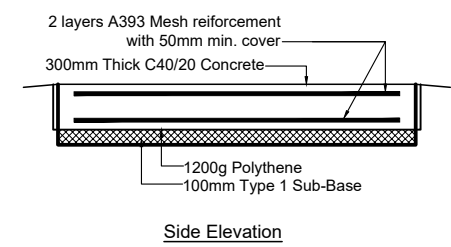
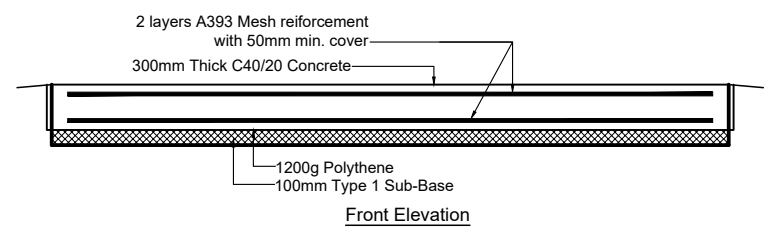

| | | | |
|--|--|--|--|
| | | | |
| | | | |

Rev: AMENDMENT DETAILS Date: Description: Approved by:



Checked by: GP Approved by: SB

ISSUED 12/05/17

Bus Stop Base for
Rural Shelter Type D
Disabled Access with Extension Panel

This is a typical detail and may require conversion to a full scheme specific drawing.

NOT TO SCALE
(all units in millimetres)

Disclaimer : Before making use of this detail, any designer or third party must ensure that it satisfies all requirements of the scheme to which it is being applied. Lincolnshire County Council accept no responsibility for third party use of this Standard Detail.

SD/11/14D
Standard Detail Number

Revision Number