

Notes

1. Finishes to be Class F2.

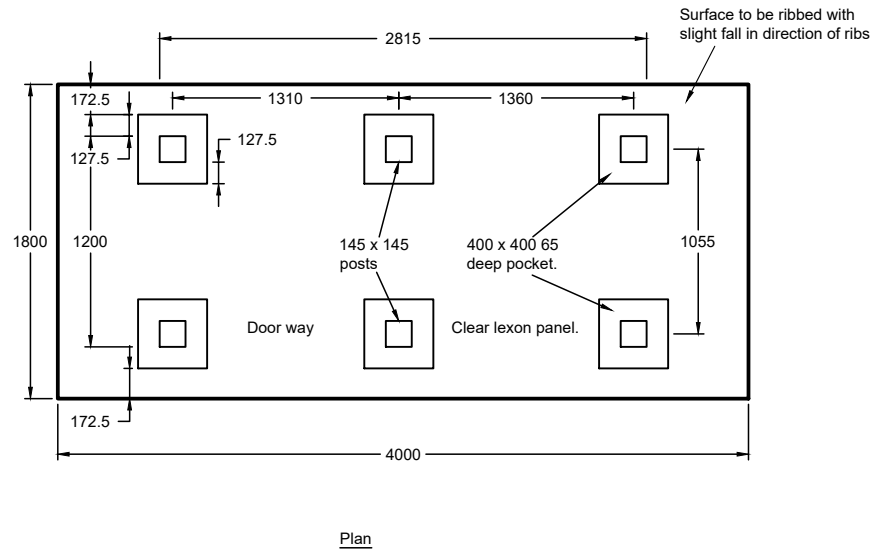
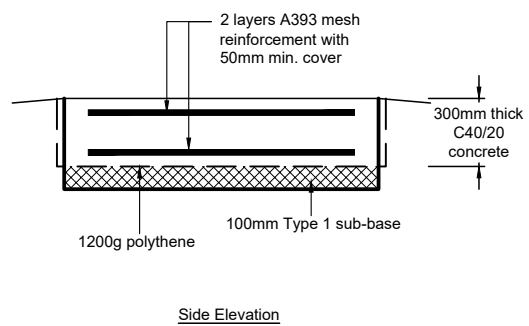
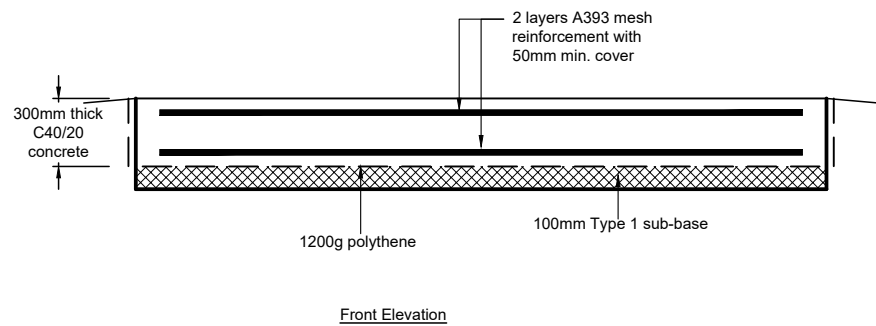

Please be aware that the supplier of the shelter that this base was intended to compliment is no longer in existence. As such, the dimensions of the base may require adjustment to allow other products to be compatible. Approval must be sought for any variation.

Rev: AMENDMENT DETAILS Date: Description: Approved by: SB



Checked by: GP Approved by: SB

ISSUED 12/05/17

Bus Stop Base for
Rural Shelter Type B

This is a typical detail and may require conversion to a full scheme specific drawing.

NOT TO SCALE
(all units in millimetres)

Disclaimer : Before making use of this detail, any designer or third party must ensure that it satisfies all requirements of the scheme to which it is being applied. Lincolnshire County Council accept no responsibility for third party use of this Standard Detail.

SD/11/14B

Standard Detail Number

Revision Number