

Type K11

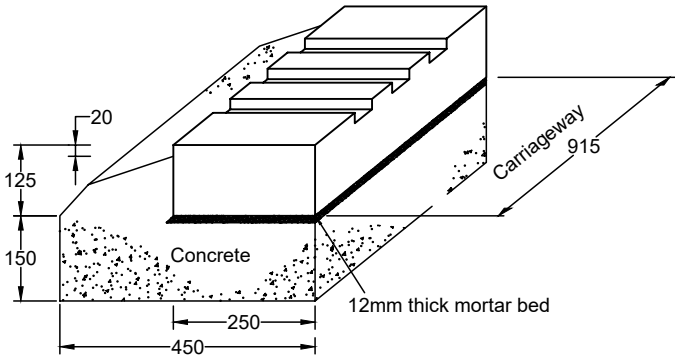

Type K12

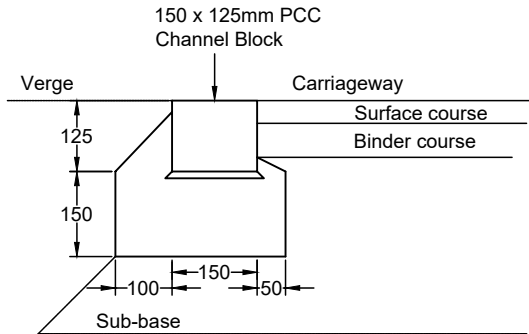

Type K13

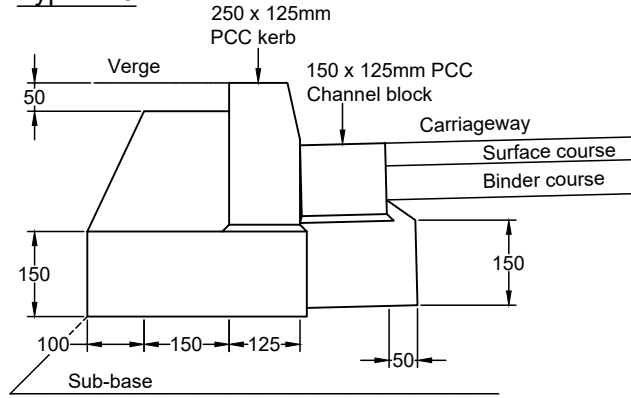

Notes

1. Precast concrete channel warning blocks 125 x 250mm to BS 7263.
2. Mortar bed and joint to be Class 1 to Clause 2404, bed thickness 10-20mm to Clause 1101.
3. Concrete Grade ST3 to BS EN 206 laid in accordance with Clause 2602.
4. Disc cut in existing carriageway to a depth of 100mm in front of channel and seal joint with hot poured bitumen using 50mm shoe.

Rev: AMENDMENT DETAILS Date: Description: Approved by:



Checked by: GP Approved by: SB

ISSUED 12/05/17

Edge of Carriageway Warning Strip and (Small Section) Channel Blocks

This is a typical detail and may require conversion to a full scheme specific drawing.

NOT TO SCALE  
(all units in millimetres)

**Disclaimer :** Before making use of this detail, any designer or third party must ensure that it satisfies all requirements of the scheme to which it is being applied. Lincolnshire County Council accept no responsibility for third party use of this Standard Detail.

**SD/11/18**  
Standard Detail Number

Revision Number