

Notes

1. 25mm thickness of 0/6mm size close graded surface course to Clause 912.
2. 80mm thickness of 0/20mm size dense binder course to Clause 906.
3. On weak ground the overall thickness of dense binder course to be increased to 100mm thick and placed in two separate 50mm layers. The lower sacrificial layer must be compacted as well as ground conditions permit and allowed to gain maximum stiffness prior to laying subsequent layers.
4. Design may not be suitable for treating soft spots, refer to dwg. no. SD/11/4.
5. Crossfall is 3% towards carriageway unless otherwise specified.
6. For precast concrete kerb, see Drawing No. SD/11/2.
7. Concrete bed and backing to Grade ST3 to Clause 2602.
8. Mortar bed to be Class 1 to Clause 2404 thickness 10-40mm to Clause 1101.
9. Precast concrete kerbs and edgings to BS 7263.
10. Softwood to be tanalised.
11. Thickness of wood to be 35mm.
12. Prepared formation to be sprayed with an approved weed killer.
13. Design is only suitable for the rehabilitation of an existing footway.

Rev: AMENDMENT DETAILS Date: Description: Approved by:



Checked by: GP Approved by: SB

ISSUED 12/05/17

Typical Cross Sections -
All Asphalt Footways

SD/11/4B
Standard Detail Number

Revision Number

Revision

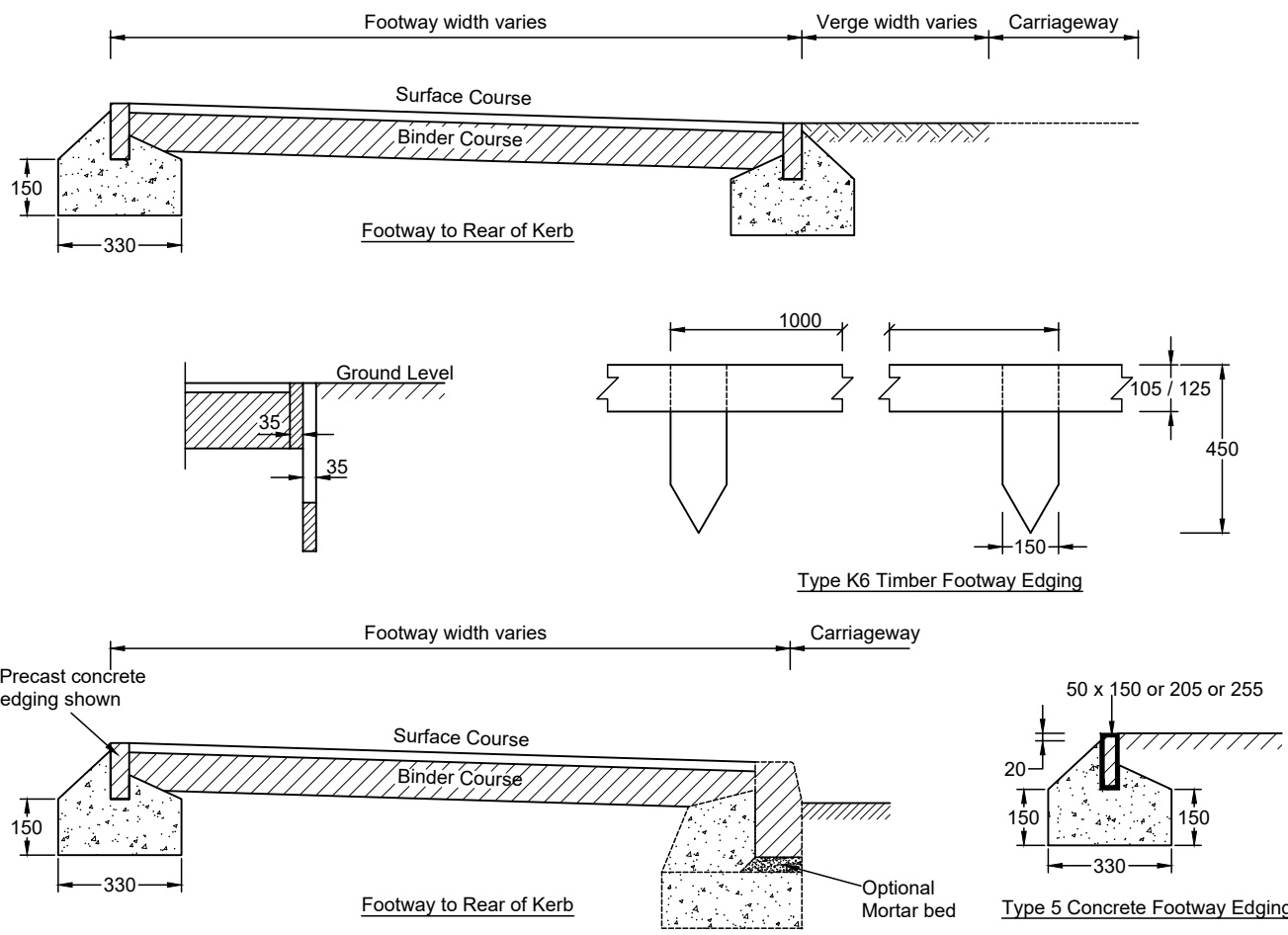

This is a typical detail and may require conversion to a full scheme specific drawing.

NOT TO SCALE
(all units in millimetres)

Disclaimer : Before making use of this detail, any designer or third party must ensure that it satisfies all requirements of the scheme to which it is being applied. Lincolnshire County Council accept no responsibility for third party use of this Standard Detail.