

Notes

1. Sub formation or formation where no capping is required shall be trimmed, rolled & protected with the initial construction layer in accordance with Clause 613 on the same day as it is exposed.
2. Where required, capping layer is to comply with Clause 613.
3. Type 1 sub-base to Clause 803.
4. Binder course to be 0/20mm dense binder course 50 pen to Cl. 702 recipe mix.
5. Surface levels of sub-base and binder course to comply with Cl. 702.
6. Bedding sand to BS 7533 shall be compacted & then the top 10mm lightly raked loose before laying of paving units.
7. Precast concrete paving blocks shall comply to Cl. 1107.
8. Dimensions, shape, colour & laying pattern of paving blocks to be as specified in contract & precast paving blocks shall be laid in accordance with BS 7533-3.

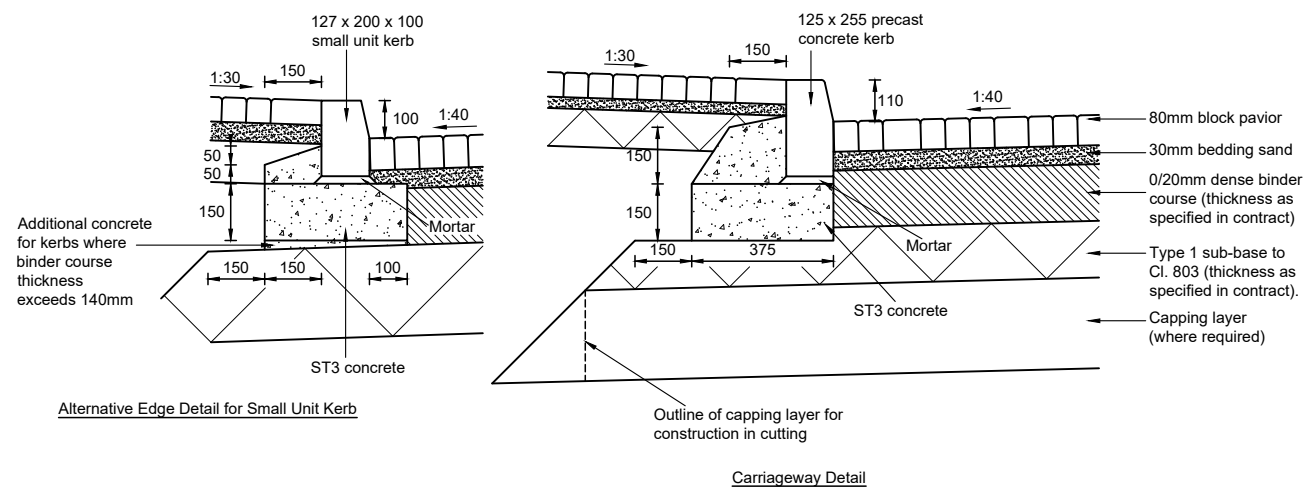

CBR	Commercial (CV/D) vehicles per day	Capping (mm)	S/B (mm)	B/C 50 pen (mm)	Surfacing (mm)		Total Thickness (mm)	
					Sand (mm)	Pavior (mm)	Surfacing B/C & S/B	Including Capping
<2%	100	340*	280	60	30	80	450	790
	200	370*	250	90	30	80	450	820
	500	430*	190	150	30	80	450	880
	1000	470*	150	190	30	80	450	920
>2% - <5%	100	240	280	60	30	80	450	690
	200	270	250	90	30	80	450	720
	500	330	190	150	30	80	450	780
	1000	370	150	190	30	80	450	820
>5% - <15%	100	-	280	60	30	80	450	-
	200	-	250	90	30	80	450	-
	500	-	245	150	30	80	505	-
	1000	-	245	190	30	80	545	-
>15%	100	-	280	60	30	80	450	-
	200	-	250	90	30	80	450	-
	500	-	190	150	30	80	450	-
	1000	-	170	190	30	80	470	-

* Geotextile to clause 609 to be incorporated at sub-formation / capping layer interface.

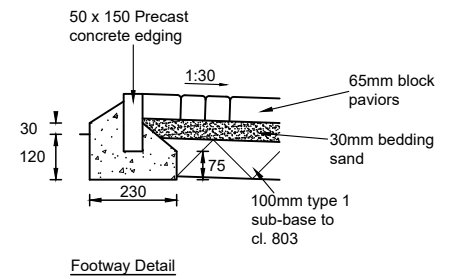

Footway Detail

This is a typical detail and may require conversion to a full scheme specific drawing.

NOT TO SCALE
(all units in millimetres)

Disclaimer : Before making use of this detail, any designer or third party must ensure that it satisfies all requirements of the scheme to which it is being applied. Lincolnshire County Council accept no responsibility for third party use of this Standard Detail.

Rev:	Date:	Description:	Approved by:
AMENDMENT DETAILS			



Checked by: GP Approved by: SB

ISSUED 12/05/17

Concrete Block Paving
Surfacing Option

SD/11/8
Standard Detail Number

Revision Number