

Type 1

Standard clip outreach with flange for posts. Type 1, 2 and 3

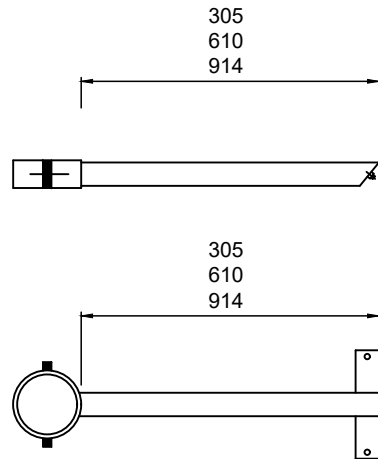

Type 2

Post top outreach with flange for posts. Type 1, 2 and 3

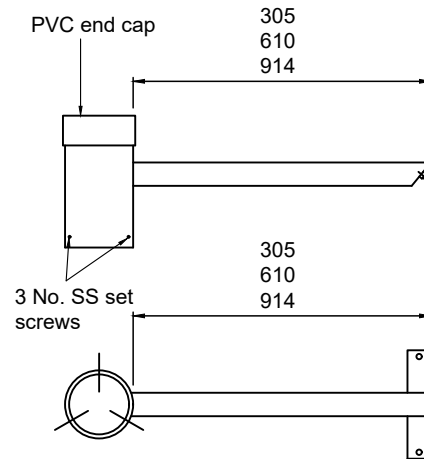

Type 3

Post top outreach with adjustable lantern fixing and flange for posts. Type 1, 2 and 3

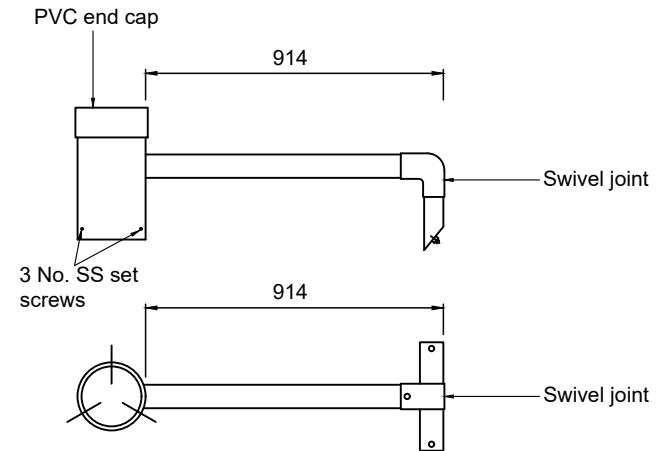

Bracket arm cut to required length

Notes

1. Material mild steel
2. Finish galvanised to BS EN ISO 1461
3. All welds to be continuous
4. Remove all sharp edges
5. All dimensions are in millimetres
6. Set screws to be of stainless steel.

This is a typical detail and may require conversion to a full scheme specific drawing.

NOT TO SCALE
(all units in millimetres)

Disclaimer : Before making use of this detail, any designer or third party must ensure that it satisfies all requirements of the scheme to which it is being applied. Lincolnshire County Council accept no responsibility for third party use of this Standard Detail.

Rev:	Date:	Description:	Approved by:
AMENDMENT DETAILS			
Checked by:	PC	Approved by:	SB
ISSUED		04/12/14	
Sign Bracket Arm Detail			
SD/14/5B			
<small>Standard Detail Number</small>		<small>Revision Number</small>	