

Type G4
Road Gully

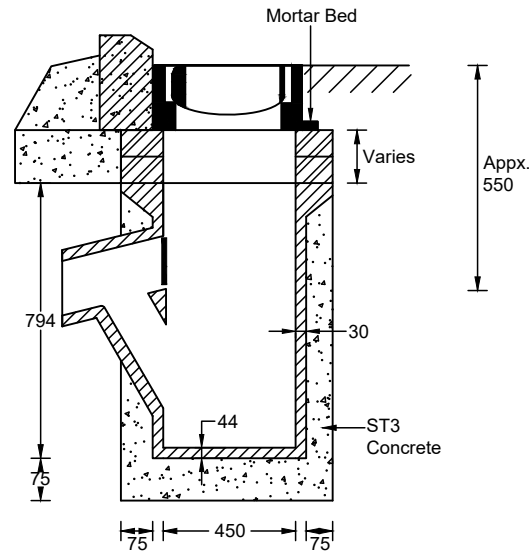

Type G5
Trapped Road Gully

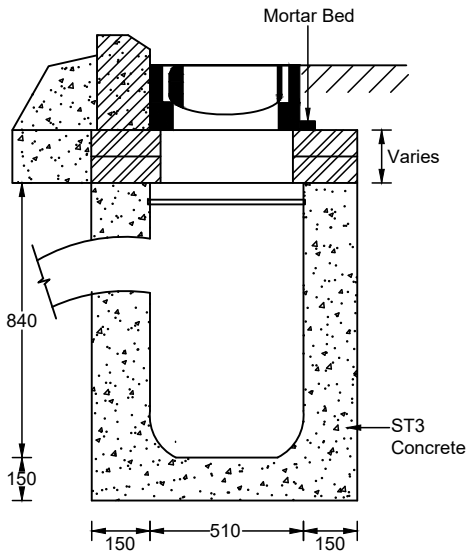

Type G6
Plastic Road Gully

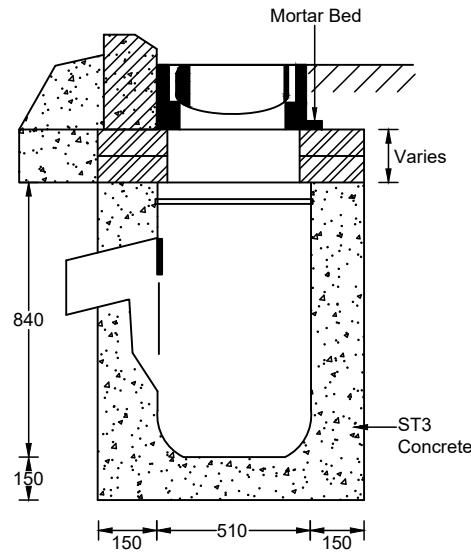

Type G7
Trapped Plastic Road Gully

Notes

1. Grating and frame uncoated iron-kite marked to BS EN124. Class D400 frames and grates.
2. Mortar bed & benching to be Class (i) to Clause 2404
3. Bricks to be Class B Engineering bricks to: BS EN 772-1, BS EN 772-3 & BS EN 772-7 (single course where necessary to obtain satisfactory fall). Corbelled if required.
- a) Class D400 frames to be bricked on four sides.
- b) Class C250 frames to be bricked on three sides.
4. Insitu surround concrete shall be ST3.
5. Position of outlet pipe varies in plan.
6. Insitu ST3 concrete 150mm thick to Clause 2602 surround to outlet pipe for first one metre under verge or total length if under carriageway.
7. Where grating is to be trafficked or laid against within 24 hours of frame being placed in position, then a suitable ultra rapid hardening mortar and concrete shall be used to bed cover and frame.

Rev:	Date:	Description:	Approved by:
AMENDMENT DETAILS			



Checked by:	GP	Approved by:	SB
-------------	----	--------------	----

ISSUED	12/05/17
--------	----------

Pre-cast Concrete and Plastic Gullies

This is a typical detail and may require conversion to a full scheme specific drawing.

NOT TO SCALE
(all units in millimetres)

Disclaimer : Before making use of this detail, any designer or third party must ensure that it satisfies all requirements of the scheme to which it is being applied. Lincolnshire County Council accept no responsibility for third party use of this Standard Detail.

SD/5/1
Standard Detail Number

Revision Number