

Section B-B  
Type G1 & G1A

Section A-A  
Type G2, G2A, G3 & G3A

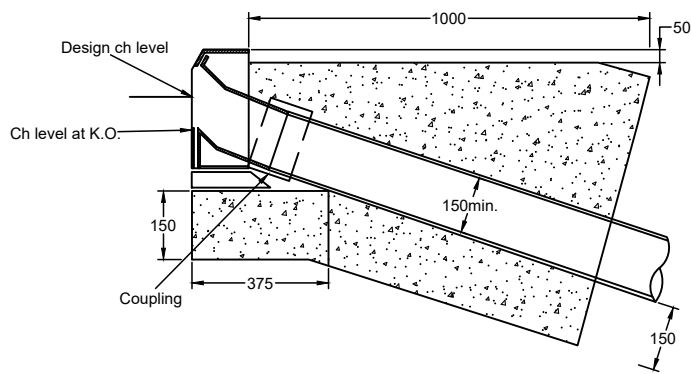

Type	Profile	Length (L)	Width (W)	Depth (D)	Length of Spigot
G1	Half Batter	375	150	250	75
G1A	45° Splay	375	150	250	75
G2	Half Batter	375	150	200	75
G2A	45° Splay	375	150	200	75
G3	Half Batter	600	150	250	75
G3A	45° Splay	600	150	250	75

- Notes**
- Concrete bed, backing and surround to be Grade ST3 (Clause 2602).
  - Mortar bed to be to Clause 2404, thickness 10-40mm (Clause 1101).
  - Outlet to be uncoated iron complying with BS EN 124.
  - 150mm diameter bore outlet.
  - Minimum gradient of outlet pipe to be 10%.
  - Proprietary pipe connections or a repair coupling (Naylors or similar) to join pipe and outlet.
  - Outlet to take a minimum wheel loading of 5 tonnes

Rev: AMENDMENT DETAILS      Date:      Description:      Approved by:



Checked by: GP      Approved by: SB

ISSUED      12/05/17

Kerb Outlet

This is a typical detail and may require conversion to a full scheme specific drawing.

NOT TO SCALE  
(all units in millimetres)

**Disclaimer :** Before making use of this detail, any designer or third party must ensure that it satisfies all requirements of the scheme to which it is being applied. Lincolnshire County Council accept no responsibility for third party use of this Standard Detail.

**SD/5/4**  
Standard Detail Number

Revision Number